

Product number	Description
GoPLe-3-10	Pressure transmitter 0-3 mtr. with E+H ceramic measuring cell and 10 mtr. PUR cable
GoPLe-5-10	Pressure transmitter 0-5 mtr with E+H ceramic measuring cell and 10 mtr PUR cable.
GoPLe-5-25	Pressure transmitter 0-5 mtr. with E+H ceramic measuring cell and 25 m. PUR cable.
GoPLe-10-25	Pressure transmitter 0-10 mtr. with E+H ceramic measuring cell and 25 m. PUR cable.
GoPLe-25-50	Pressure transmitter 0-25 mtr. with E+H ceramic measuring cell and 50 mtr. PUR cable.
GoPLe-30-35	Pressure transmitter 0-30 mtr. with E+H ceramic measuring cell and 35 m. PUR cable.
GoPLe-50-50	Pressure transmitter 0-50 mtr. with E+H ceramic measuring cell and 50 mtr. PUR cable.

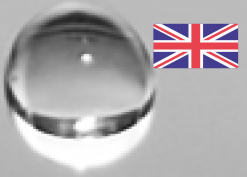

GoPLe Quickguide

About GoPle

ACOWA GoPle is used for level measurement in waste water and water supply applications.

GoPle is known for its high reliability and stability in regards to level measurements.

GoPle use a ceramic capacitive measurement principle, where it converts the immersion of the sensor in the liquid, into a 4-20mA current loop.

GoPle comes in 3 range versions and with fixed cable length. Individual measuring range and cable length can be offered on request.

Applications

GoPle is designed for use in waste water and water supply applications.

- Water wells, basins and tanks
- Sewage wells
- Mini pumping stations
- Tank monitoring
- Level monitoring

Features

- Diameter: Ø27
- Robust design
- Long service life
- E+H ceramic measuring cell
- CE certified

Installation and specifications

For installation of the GoPle, the following specifications may be required.

NOTE! GoPle is not EX-rated and therefore cannot be used for installation in EX areas.

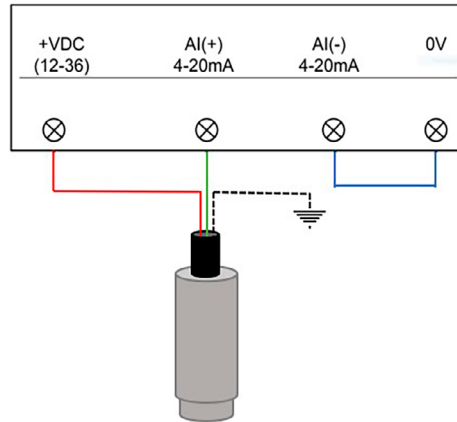

Materials	Housing in stainless steel
Measuring range	0-3m, 0-5m or 0-10m
Measuring principle	Ceramic capacitive
Output signal	4-20mA
Accuracy better than	0.5 %FS at -10 - +60C°
Long term stability	Better than 0,25% FS per year
Supply voltage	12-36V DC
Temperature range	-40C° - +80C°
Resistance	100MΩ@ 50V DC
Enclosure class	IP68
Membrane material	E&H ceramic measuring cell
Response time	10ms
Length of cable	10m
Type of cable	Highly flexible PUR cable with screen
Total weight	760g